



Phone: 1300 672 937

E-mail: garments@opchealth.com.au



# Lymphology

Date: .....

Order  Quotation only

Company stamp, phone (in block letters)	<b>Patient details</b> <input type="checkbox"/> Photo documentation will follow by e-mail <sup>1</sup>	
	Order no.?: .....	<input type="checkbox"/> Female <input type="checkbox"/> Male <input type="checkbox"/> Diverse
	Order number / process number: .....	Previous order no. / Quotation no. / Date: .....
	Contact person:	Quantity: ..... Piece ..... Customer no.: .....

Fabric	mmHg	18 - 21	23 - 32
		CCL 1	CCL 2
Juzo Expert		<input type="checkbox"/> 3021	<input type="checkbox"/> 3022
Juzo Expert Silver		<input type="checkbox"/> 3021	<input type="checkbox"/> 3022
Juzo Expert Cotton		<input type="checkbox"/> 3021	<input type="checkbox"/> 3022
Juzo Expert Strong		<input type="checkbox"/> 3051	<input type="checkbox"/> 3052
Juzo Expert Strong Silver		<input type="checkbox"/> 3051	<input type="checkbox"/> 3052

**Colour** If not indicated we will deliver colour Almond. Silver and Cotton available in colour Almond.

Sugar  Sesame  Almond  Cinnamon  
 Cacao  Poppy seed  Blueberry  Black pepper  
 Trend Colours .....

**Customisation options foot**

Open toes  
 Closed toes

With opening at little toe (5)  
 Slanted opening (standard)  
 Straight opening

To be worn in combination with compression stocking  
 Compression stocking with knitted-on toe portion  
 Seams on the outside

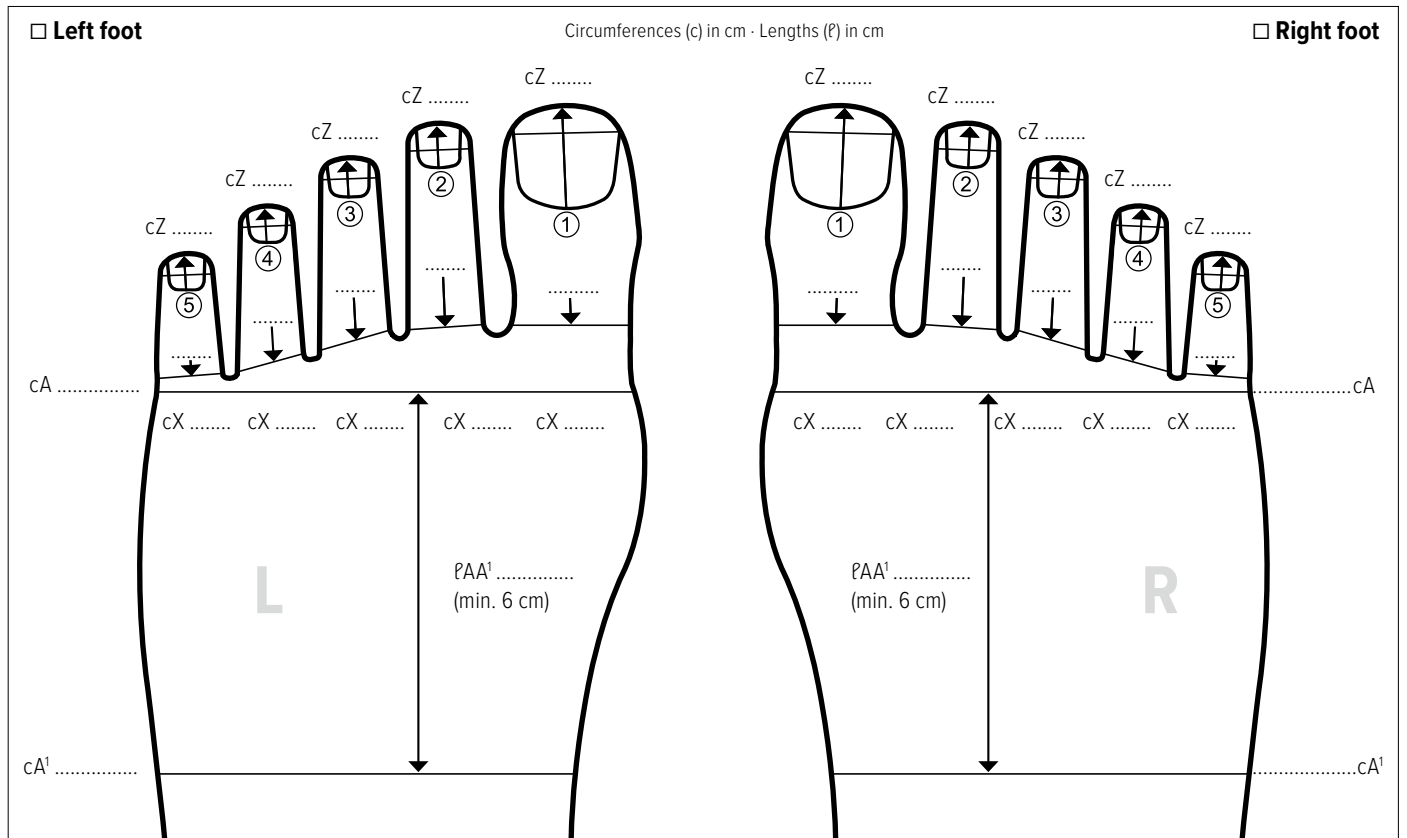

Special requests (in block letters):

Please send a new order form

.....

.....

.....

.....

.....

.....

.....

.....

.....

.....



<sup>1</sup> Due to the principle of data minimisation under data protection law, we recommend that you only send in a photo in the case of difficult anatomical features.  
<sup>2</sup> If the patient name is provided, the company placing the order confirms that it has obtained lawful consent in advance to forward and process the data of the affected patient.